

Non-metallic Optical Strain Gage | os3200

Applications

- Industrial grade strain gages for automotive, aircraft/aerospace, structural, geotechnical, energy and medical equipment monitoring applications
- Core building block for higher level sensors such as accelerometers, inclinometers, displacement, pressure, load sensors and many other transducers

Features

- Multi-Sensor Arrays: Easily facilitates many sensors on a single optical connection
- Remote Sensing: Long distances between sensors or between sensors and instrument
- Easy to Install: In most cases, can be mounted directly to concrete or composite structures
- Simple, Low Cost Installation: Due to multi-sensor array feature
- Non-Electrical Sensor Design: Eliminates ESD and spark hazard, and immune to electromagnetic interference
- Small in size, made of optical fiber, no electromagnetic field generation by the sensor

Description

The os3200 Optical Strain Gage is a revolutionary product based on Micron Optics' patented micro opto-mechanical technology.

The os3200 provides an ideal alternative to electrical strain sensors, featuring advantages such as speed of installation, high accuracy, long-term stability, premium performance, and world record resistance to mechanical fatigue. Installation is easy as the os3200 can be mounted to most materials using conventional techniques. A professional installation kit is also available from Micron Optics.



This sensor can be used alone or in series as part of an FBG sensor array. The os3200 is an industrial grade design targeting the harsh environments found in Energy, Civil, Transportation, Aerospace and Military applications. The os3200 sensor demonstrates excellent compatibility with Micron Optics sensing instruments.

Non-metallic Optical Strain Gage | os3200

Specifications ^β1

os3200

Performance Properties

Gage Type	Surface-Mount Non-Metallic Strain Gage
Strain Sensitivity	~ 1.2 pm/με
Active Gage Length	10 mm
Operating Temperature Range ²	-40 to 60° C (80°C Max)
Strain Limits	± 5,000 με
Maximum Drift ³	< 50 με

Physical Properties

Dimensions	25 mm x 6 mm x 1 mm
Weight	1.0 g
Cable Length	1 m (± 10 cm), each end
Fiber Type	SMF28-Compatible
Fiber Coating	Polyimide
Buffer Tube	0.9 mm Fiberglass Braid
Connectors	FC/APC optional
Installation Kit	Optional

Optical Properties

Center Wavelength (± 1 nm)	1462nm to 1618nm available (± 1 nm)
Peak Reflectivity (Rmax)	> 70%
FWHM (-3 dB point)	0.25 nm (± .05 nm; apodized grating)
Isolation	> 12 dB (@ ± 0.4 nm around center wavelength)

Notes:

1. Denotes Beta product. For more details see www.micronoptics.com/product_designation.php.
2. Prolonged exposure to maximum temperature could reduce performance.
3. 40 temperature cycles -40 to 60° C

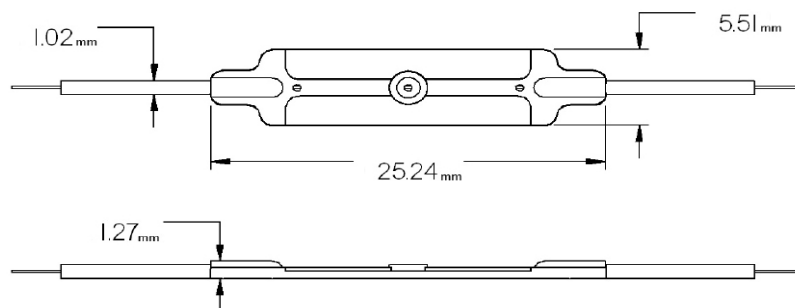

Ordering Information

os3200 - **www** - 1xx - 1yy (Example: os3200 -1560-1FC- 1FC)

www : Wavelength (nm) Standard wavelengths: 1512nm to 1588 in 4nm intervals.	1xx : Cable 1, Length & Connector 1 1m standard, Cable Length UT Underterminated FC FC/APC Connector	1yy : Cable 2, Length & Connector 1 1m standard, Cable Length UT Underterminated FC FC/APC Connector
-------------------------------------------------------------------------------------------	------------------------------------------------------------------------------------------------------------------------------------	------------------------------------------------------------------------------------------------------------------------------------